

CMOS Hex Buffer/Converter

The CD4049UBMS is an inverting hex buffer and features logic level conversion using only one supply (voltage (VCC)). The input signal high level (VIH) can exceed the VCC supply voltage when this device is used for logic level conversions. This device is intended for use as CMOS to DTL/TTL converters and can drive directly two DTL/TTL loads. (VCC = 5V, VOL ≤ 0.4V, and IOL ≥ 3.3mA.

The CD4049UBMS is designated as replacement for CD4009UB. Because the CD4049UBMS requires only one power supply, it is preferred over the CD4009UB and CD4010B and should be used in place of the CD4009UB in all inverter, current driver, or logic level conversion applications. In these applications the CD4049UBMS is pin compatible with the CD4009UB, and can be substituted for this device in existing as well as in new designs. Terminal No. 16 is not connected internally on the CD4049UBMS, therefore, connection to this terminal is of no consequence to circuit operation. For applications not requiring high sink current or voltage conversion, the CD4069UB Hex Inverter is recommended.

The CD4049UBMS is supplied in these 16 lead outline packages:

- Braze Seal DIP H4S
- Frit Seal DIP H1E
- Ceramic Flatpack H3X

Functional Diagram

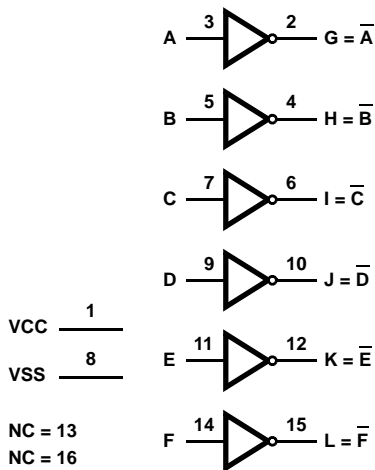

Features

- High Voltage Type (20V Rating)
- Inverting Type
- High Sink Current for Driving 2 TTL Loads
- High-to-Low Level Logic Conversion
- 100% Tested for Quiescent Current at 20V
- Maximum Input Current of 1mA at 18V Over Full Package Temperature Range; 100nA at 18V and +25°C
- 5V, 10V and 15V Parametric Ratings

Applications

- CMOS to DTL/TTL Hex Converter
- CMOS Current “Sink” or “Source” Driver
- CMOS High-to-Low Logic Level Converter

Pinout

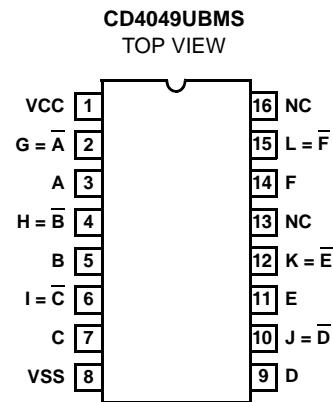

Schematic

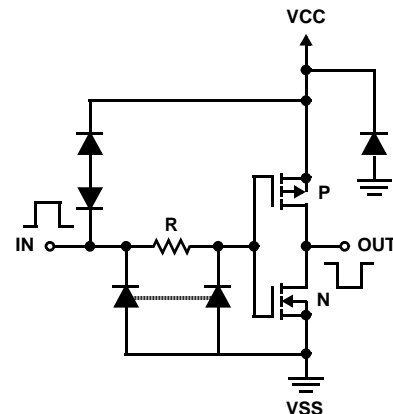

FIGURE 1. SCHEMATIC DIAGRAM, 1 OF 6 IDENTICAL UNITS

CD4049UBMS

Ordering Information

PART NUMBER	PART MARKING	TEMP. RANGE (°C)	PACKAGE	PKG. DWG. #
CD4049UBDMSR	Q 5962R96 63601VEC	-55 to +125	16 Ld SBDIP, Solder Seal	D16.3
CD4049UBKMSR	Q 5962R96 63601VXC	-55 to +125	16 Ld Flatpack, Solder Seal	K16.A
CD4049UBKNSR	Q 5962R96 63602VXC	-55 to +125	16 Ld Flatpack, Solder Seal	K16.A

CD4049UBMS

Absolute Maximum Ratings

DC Supply Voltage Range, (V_{DD}) -0.5V to +20V
 (Voltage Referenced to VSS Terminals)
 Input Voltage Range, All Inputs -0.5V to 20.5V
 DC Input Current, Any One Input ± 10 mA
 Operating Temperature Range -55°C to +125°C
 Package Types D, F, K, H
 Storage Temperature Range (TSTG) -65°C to +150°C
 Lead Temperature (During Soldering) +265°C
 At Distance 1/16 \pm 1/32 Inch (1.59mm \pm 0.79mm) from case for
 10s Maximum

Thermal Information

Thermal Resistance (Typical) θ_{JA} (°C/W) θ_{JC} (°C/W)
 Ceramic DIP and FRIT Package 80 20
 Flatpack Package 70 20
 Maximum Package Power Dissipation (PD) at +125°C
 For $T_A = -55^\circ\text{C}$ to +100°C (Package Type D, F, K) 500mW
 For $T_A = +100^\circ\text{C}$ to +125°C (Package Type D, F, K) Derate
 Linearity at 12mW/°C to 200mW
 Device Dissipation per Output Transistor 100mW
 For $T_A =$ Full Package Temperature Range (All Package Types)
 Junction Temperature +175°C

DC Electrical Specifications

PARAMETER	SYMBOL	CONDITIONS (Note 1)		GROUP A SUBGROUPS	TEMP (°C)	LIMITS		UNITS
						MIN	MAX	
Supply Current	I_{DD}	$V_{DD} = 20\text{V}$, $V_{IN} = V_{DD}$ or GND		1	+25	-	2	μA
				2	+125	-	200	μA
		$V_{DD} = 18\text{V}$, $V_{IN} = V_{DD}$ or GND		3	+55	-	2	μA
Input Leakage Current	I_{IL}	$V_{IN} = V_{DD}$ or GND	$V_{DD} = 20$	1	+25	-100	-	nA
				2	+125	-1000	-	nA
			$V_{DD} = 18\text{V}$	3	-55	-100	-	nA
Input Leakage Current	I_{IH}	$V_{IN} = V_{DD}$ or GND	$V_{DD} = 20$	1	+25	-	100	nA
				2	+125	-	1000	nA
			$V_{DD} = 18\text{V}$	3	+55	-	100	nA
Output Voltage	V_{OL15}	$V_{DD} = 15\text{V}$, No Load		1, 2, 3	+25, +125, -55	-	50	mV
Output Voltage	V_{OH15}	$V_{DD} = 15\text{V}$, No Load (Note 3)		1, 2, 3	+25, +125, -55	14.95	-	V
Output Current (Sink)	I_{OL4}	$V_{DD} = 4.5\text{V}$, $V_{OUT} = 0.4\text{V}$		1	+25	2.6	-	mA
Output Current (Sink)	I_{OL5}	$V_{DD} = 5\text{V}$, $V_{OUT} = 0.4\text{V}$		1	+25	3.2	-	mA
Output Current (Sink)	I_{OL10}	$V_{DD} = 10\text{V}$, $V_{OUT} = 0.5\text{V}$		1	+25	8.0	-	mA
Output Current (Sink)	I_{OL15}	$V_{DD} = 15\text{V}$, $V_{OUT} = 1.5\text{V}$		1	+25	24	-	mA
Output Current (Source)	I_{OH5A}	$V_{DD} = 5\text{V}$, $V_{OUT} = 4.6\text{V}$		1	+25	-	-0.8	mA
Output Current (Source)	I_{OH5B}	$V_{DD} = 5\text{V}$, $V_{OUT} = 2.5\text{V}$		1	+25	-	-3.2	mA
Output Current (Source)	I_{OH10}	$V_{DD} = 10\text{V}$, $V_{OUT} = 9.5\text{V}$		1	+25	-	-1.8	mA
Output Current (Source)	I_{OH15}	$V_{DD} = 15\text{V}$, $V_{OUT} = 13.5\text{V}$		1	+25	-	-6.0	mA
N Threshold Voltage	V_{NTH}	$V_{DD} = 10\text{V}$, $I_{SS} = -10\mu\text{A}$		1	+25	-2.8	-0.7	V
P Threshold Voltage	V_{PTH}	$V_{SS} = 0\text{V}$, $I_{DD} = 10\mu\text{A}$		1	+25	0.7	2.8	V
Functional	F	$V_{DD} = 2.8\text{V}$, $V_{IN} = V_{DD}$ or GND		7	+25	$V_{OH} > V_{DD}/2$	$V_{OL} < V_{DD}/2$	V
		$V_{DD} = 20\text{V}$, $V_{IN} = V_{DD}$ or GND		7	+25			
		$V_{DD} = 18\text{V}$, $V_{IN} = V_{DD}$ or GND		8A	+125			
		$V_{DD} = 3\text{V}$, $V_{IN} = V_{DD}$ or GND		8B	-55			

CD4049UBMS

DC Electrical Specifications

PARAMETER	SYMBOL	CONDITIONS (Note 1)	GROUP A SUBGROUPS	TEMP (°C)	LIMITS		UNITS
					MIN	MAX	
Input Voltage Low (Note 2)	V _{IL}	V _{DD} = 5V, V _{OH} > 4.5V, V _{OL} < 0.5V	1, 2, 3	+25, +125, -55	-	1.0	V
Input Voltage High (Note 2)	V _{IH}	V _{DD} = 5V, V _{OH} > 4.5V, V _{OL} < 0.5V	1, 2, 3	+25, +125, -55	4.0	-	V
Input Voltage Low (Note 2)	V _{IL}	V _{DD} = 15V, V _{OH} > 13.5V, V _{OL} < 1.5V	1, 2, 3	+25, +125, -55	-	2.5	V
Input Voltage High (Note 2)	V _{IH}	V _{DD} = 15V, V _{OH} > 13.5V, V _{OL} < 1.5V	1, 2, 3	+25, +125, -55	12.5	-	V

NOTES:

1. All voltages referenced to device GND, 100% testing being implemented.
2. Go/No Go test with limits applied to inputs.
3. For accuracy, voltage is measured differentially to V_{DD}. Limit is 0.050V max.

AC Electrical Specifications

PARAMETER	SYMBOL	CONDITIONS (Notes 4, 5)	GROUP A SUBGROUPS	TEMP (°C)	LIMITS		UNITS
					MIN	MAX	
Propagation Delay	t _{PHL}	V _{DD} = 5V, V _{IN} = V _{DD} or GND	9	+25	-	65	ns
			10, 11	+125, -55	-	88	ns
Propagation Delay	t _{PLH}	V _{DD} = 5V, V _{IN} = V _{DD} or GND	9	+25	-	120	ns
			10, 11	+125, -55	-	162	ns
Transition Time	t _{THL}	V _{DD} = 5V, V _{IN} = V _{DD} or GND	9	+25	-	60	ns
			10, 11	+125, -55	-	81	ns
Transition Time	t _{TLH}	V _{DD} = 5V, V _{IN} = V _{DD} or GND	9	+25	-	160	ns
			10, 11	+125, -55	-	216	ns

NOTES:

4. C_L = 50pF, R_L = 200k, Input t_R, t_F < 20ns.
5. -55°C and +125°C limits guaranteed, 100% testing being implemented.

Post Irradiation Electrical Performance Characteristics

PARAMETER	SYMBOL	CONDITIONS	NOTES	TEMP (°C)	LIMITS		UNITS
					MIN	MAX	
Supply Current	I _{DD}	V _{DD} = 5V, V _{IN} = V _{DD} or GND	6, 7	-55, +25	-	1	μA
				+125	-	30	μA
		V _{DD} = 10V, V _{IN} = V _{DD} or GND	6, 7	-55, +25	-	2	μA
				+125	-	60	μA
		V _{DD} = 15V, V _{IN} = V _{DD} or GND	6, 7	-55, +25	-	2	μA
				+125	-	120	μA
Output Voltage	V _{OL}	V _{DD} = 5V, No Load	6, 7	+25, +125, -55	-	50	mV
Output Voltage	V _{OL}	V _{DD} = 10V, No Load	6, 7	+25, +125, -55	-	50	mV
Output Voltage	V _{OH}	V _{DD} = 5V, No Load	6, 7	+25, +125, -55	4.95	-	V
Output Voltage	V _{OH}	V _{DD} = 10V, No Load	6, 7	+25, +125, -55	9.95	-	V

CD4049UBMS

Post Irradiation Electrical Performance Characteristics

PARAMETER	SYMBOL	CONDITIONS	NOTES	TEMP (°C)	LIMITS		UNITS
					MIN	MAX	
Output Current (Sink)	I _{OL4}	V _{DD} = 4.5V, V _{OUT} = 0.4V	6, 7	+125	1.8	-	mA
				-55	3.3	-	mA
Output Current (Sink)	I _{OL5}	V _{DD} = 5V, V _{OUT} = 0.4V	6, 7	+125	2.4	-	mA
				-55	4.0	-	mA
Output Current (Sink)	I _{OL10}	V _{DD} = 10V, V _{OUT} = 0.5V	6, 7	+125	5.6	-	mA
				-55	10	-	mA
Output Current (Sink)	I _{OL15}	V _{DD} = 15V, V _{OUT} = 1.5V	6, 7	+125	18	-	mA
				-55	26	-	mA
Output Current (Source)	I _{OH5A}	V _{DD} = 5V, V _{OUT} = 4.6V	6, 7	+125	-	-0.48	mA
				-55	-	-0.81	mA
Output Current (Source)	I _{OH5B}	V _{DD} = 5V, V _{OUT} = 2.5V	6, 7	+125	-	-1.55	mA
				-55	-	-2.6	mA
Output Current (Source)	I _{OH10}	V _{DD} = 10V, V _{OUT} = 9.5V	6, 7	+125	-	-1.18	mA
				-55	-	-2.0	mA
Output Current (Source)	I _{OH15}	V _{DD} = 15V, V _{OUT} = 13.5V	6, 7	+125	-	-3.1	mA
				-55	-	-5.2	mA
Input Voltage Low	V _{IL}	V _{DD} = 10V, V _{OH} > 9V, V _{OL} < 1V	6, 7	+25, +125, -55	-	2	V
Input Voltage High	V _{IH}	V _{DD} = 10V, V _{OH} > 9V, V _{OL} < 1V	6, 7	+25, +125, -55	8	-	V
Propagation Delay	t _{PHL}	V _{IN} = 10V, V _{DD} = 5V	6, 7, 8	+25	-	30	ns
		V _{IN} = 10V, V _{DD} = 10V	6, 7, 8	+25	-	40	ns
Propagation Delay	t _{PLH}	V _{IN} = 10V, V _{DD} = 5V	6, 7, 8	+25	-	90	ns
		V _{IN} = 10V, V _{DD} = 10V	6, 7, 8	+25	-	65	ns
Propagation Delay	t _{PHL}	V _{IN} = 15V, V _{DD} = 5V	6, 7, 8	+25	-	20	ns
		V _{IN} = 15V, V _{DD} = 15V	6, 7, 8	+25	-	30	ns
Propagation Delay	t _{PLH}	V _{IN} = 15V, V _{DD} = 5V	6, 7, 8	+25	-	90	ns
		V _{IN} = 15V, V _{DD} = 15V	6, 7, 8	+25	-	50	ns
Transition Time	t _{THL}	V _{DD} = 10V, V _{IN} = V _{DD} OR GND	6, 7, 8	+25	-	40	ns
		V _{DD} = 15V, V _{IN} = V _{DD} OR GND	6, 7, 8	+25	-	30	ns
Transition Time	t _{TLH}	V _{DD} = 10V, V _{IN} = V _{DD} OR GND	6, 7, 8	+25	-	80	ns
		V _{DD} = 15V, V _{IN} = V _{DD} OR GND	6, 7, 8	+25	-	60	ns
Input Capacitance	C _{IN}	Any Input	6, 7	+25	-	22.5	pF

NOTES:

6. All voltages referenced to device GND.
7. The parameters listed on Table 3 are controlled via design or process and are not directly tested. These parameters are characterized on initial design release and upon design changes which would affect these characteristics.
8. C_L = 50pF, R_L = 200k, Input t_R, t_F < 20ns.

Post Irradiation Electrical Performance Characteristics

PARAMETER	SYMBOL	CONDITIONS	NOTES	TEMP (°C)	LIMITS		UNITS
					MIN	MAX	
Supply Current	I _{DD}	V _{DD} = 20V, V _{IN} = V _{DD} or GND	9, 12	+25	-	7.5	μA
N Threshold Voltage	V _{NTH}	V _{DD} = 10V, I _{SS} = -10μA	9, 12	+25	-2.8	-0.2	V
N Threshold Voltage Delta	ΔV _{TND}	V _{DD} = 10V, I _{SS} = -10μA	9, 12	+25	-	±1	V
P Threshold Voltage	V _{TP}	V _{SS} = 0V, I _{DD} = 10μA	9, 12	+25	0.2	2.8	V
P Threshold Voltage Delta	ΔV _{TPD}	V _{SS} = 0V, I _{DD} = 10μA	9, 12	+25	-	±1	V
Functional	F	V _{DD} = 18V, V _{IN} = V _{DD} or GND	9	+25	V _{OH} > V _{DD} /2	V _{OL} < V _{DD} /2	V
		V _{DD} = 3V, V _{IN} = V _{DD} or GND					
Propagation Delay Time	t _{PHL} t _{PLH}	V _{DD} = 5V	9, 10, 11, 12	+25	-	1.35 x +25 Limit	ns

NOTES:

- 9. All voltages referenced to device GND.
- 10. C_L = 50pF, R_L = 200k, Input t_R, t_F < 20ns.
- 11. See Table 2 for +25°C limit.
- 12. Read and Record

TABLE 1. BURN-IN AND LIFE TEST DELTA PARAMETERS +25°C

PARAMETER	SYMBOL	DELTA LIMIT
Supply Current - MSI-1	I _{DD}	± 0.2μA
Output Current (Sink)	I _{OL5}	± 20% x Pre-Test Reading
Output Current (Source)	I _{OH5A}	± 20% x Pre-Test Reading

TABLE 2. APPLICABLE SUBGROUPS

CONFORMANCE GROUP	MIL-STD-883 METHOD	GROUP A SUBGROUPS	READ AND RECORD
Initial Test (Pre Burn-In)	100% 5004	1, 7, 9	IDD, IOL5, IOH5A
Interim Test 1 (Post Burn-In)	100% 5004	1, 7, 9	IDD, IOL5, IOH5A
Interim Test 2 (Post Burn-In)	100% 5004	1, 7, 9	IDD, IOL5, IOH5A
PDA (Note 13)	100% 5004	1, 7, 9, Deltas	
Interim Test 3 (Post Burn-In)	100% 5004	1, 7, 9	IDD, IOL5, IOH5A
PDA (Note 13)	100% 5004	1, 7, 9, Deltas	
Final Test	100% 5004	2, 3, 8A, 8B, 10, 11	
Group A	Sample 5005	1, 2, 3, 7, 8A, 8B, 9, 10, 11	
Group B	Subgroup B-5	1, 2, 3, 7, 8A, 8B, 9, 10, 11, Deltas	Subgroups 1, 2, 3, 9, 10, 11
	Subgroup B-6	1, 7, 9	
Group D	Sample 5005	1, 2, 3, 8A, 8B, 9	Subgroups 1, 2, 3

NOTES:

- 13. 1. 5% Parametric, 3% Functional; Cumulative for Static 1 and 2.

TABLE 3. TOTAL DOSE IRRADIATION

CONFORMANCE GROUPS	MIL-STD-883 METHOD	TEST		READ AND RECORD	
		PRE-IRRAD	POST-IRRAD	PRE-IRRAD	POST-IRRAD
Group E Subgroup 2	5005	1, 7, 9	Table 4	1, 9	Table 4

TABLE 4. BURN-IN AND IRRADIATION TEST CONNECTIONS

FUNCTION	OPEN	GROUND	VDD	9V ± 0.5V	OSCILLATOR	
					50kHz	25kHz
Static Burn-In 1 (Note 14)	2, 4, 6, 10, 12, 13, 15	3, 5, 7-9, 11-14	1, 16			
Static Burn-In 2 (Note 14)	2, 4, 6, 10, 12, 13, 15	8	1, 3, 5, 7, 9, 11, 14, 16			
Dynamic Burn-In (Note 16)	13	8	1, 16	2, 4, 6, 10, 12, 15	3, 5, 7, 9, 11, 14	
Irradiation (Note 15)	2, 4, 6, 10, 12, 13, 15, 16	8	1, 3, 5, 7, 9, 11, 14			

NOTES:

- 14. Each pin except pin 1, pin 16, and GND will have a series resistor of $10k \pm 5\%$, $V_{DD} = 18V \pm 0.5V$
- 15. Each pin except pin 1, pin 16, and GND will have a series resistor of $47k \pm 5\%$; Group E, Subgroup 2, sample size is 4 dice/wafer, 0 failures, $V_{DD} = 10V \pm 0.5V$
- 16. Each pin except pin 1, pin 16, and GND will have a series resistor of $4.75k \pm 5\%$, $V_{DD} = 18V \pm 0.5V$

Typical Performance Characteristics

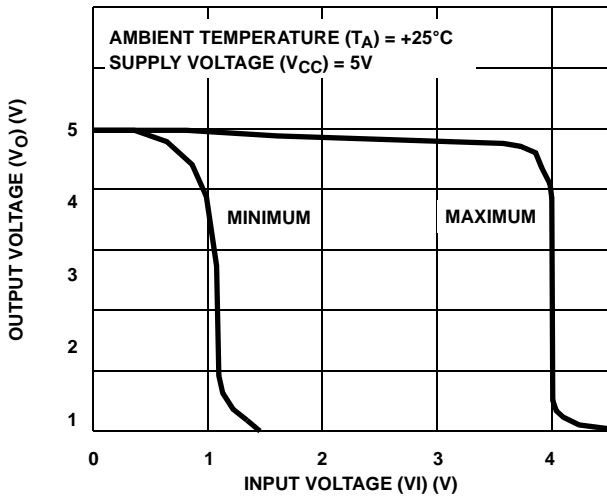

FIGURE 2. MINIMUM AND MAXIMUM VOLTAGE TRANSFER CHARACTERISTICS

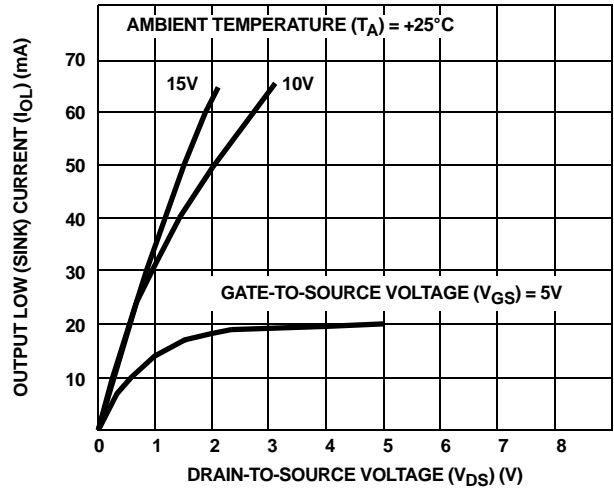

FIGURE 3. TYPICAL OUTPUT LOW (SINK) CURRENT CHARACTERISTICS

Typical Performance Characteristics (Continued)

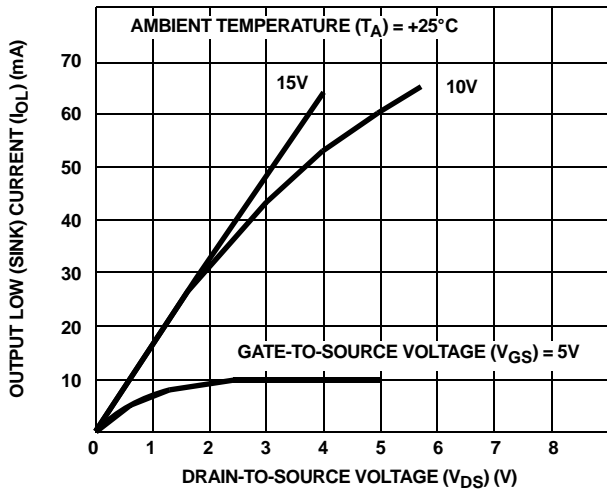

FIGURE 4. MINIMUM OUTPUT LOW (SINK) CURRENT DRAIN CHARACTERISTICS

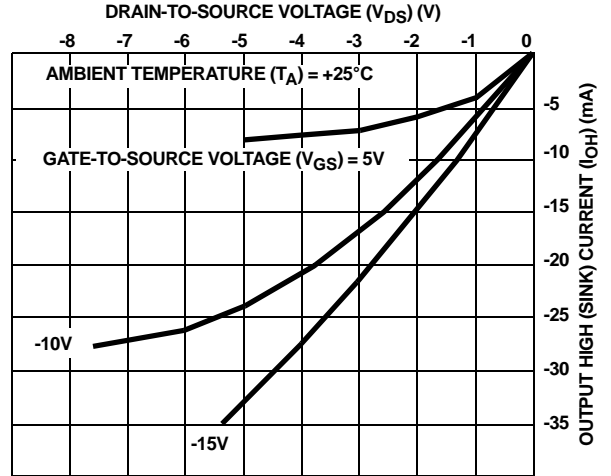

FIGURE 5. TYPICAL OUTPUT HIGH (SOURCE) CURRENT CHARACTERISTICS

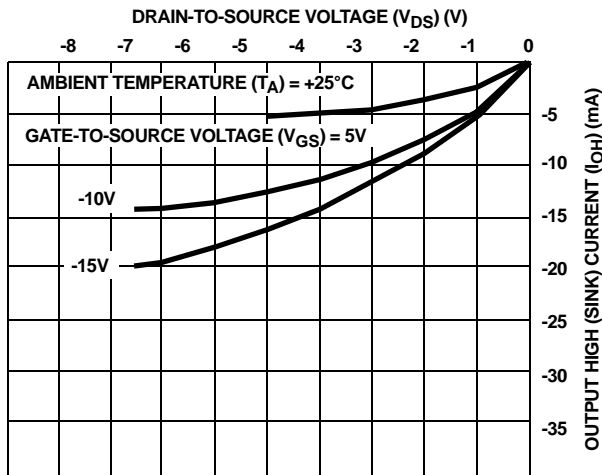

FIGURE 6. MINIMUM OUTPUT HIGH (SOURCE) CURRENT CHARACTERISTICS

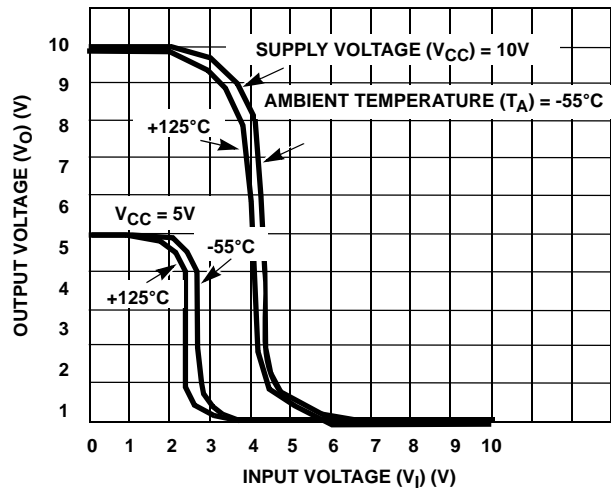

FIGURE 7. TYPICAL VOLTAGE TRANSFER CHARACTERISTICS AS A FUNCTION OF TEMPERATURE

Typical Performance Characteristics (Continued)

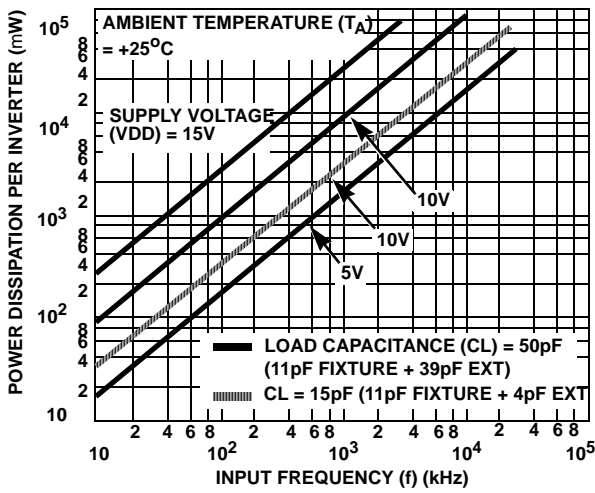

FIGURE 8. TYPICAL POWER DISSIPATION vs FREQUENCY CHARACTERISTICS

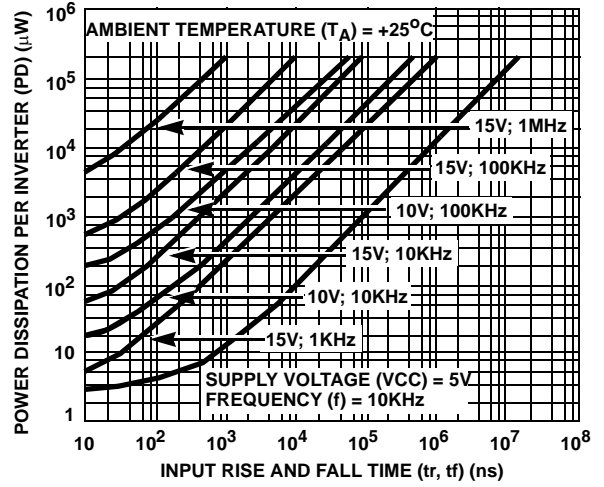
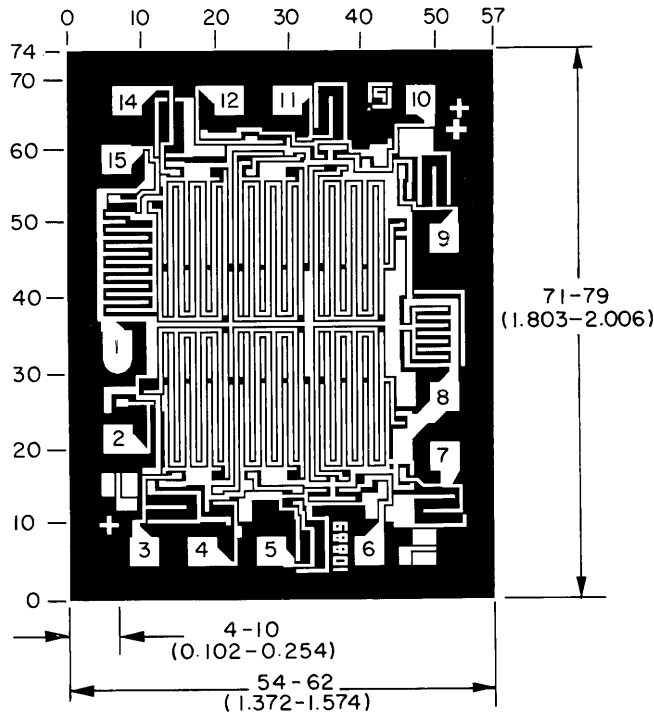

FIGURE 9. TYPICAL POWER DISSIPATION vs INPUT RISE AND FALL TIMES PER INVERTER

Chip Dimensions and Pad Layout



Dimensions in parenthesis are in millimeters and are derived from the basic inch dimensions as indicated. Grid graduations are in mils (10^{-3} inch).

METALLIZATION: Thickness: $11\text{k}\text{\AA} - 14\text{k}\text{\AA}$, AL.

PASSIVATION: $10.4\text{k}\text{\AA} - 15.6\text{k}\text{\AA}$, Silane

BOND PADS: 0.004 inches X 0.004 inches MIN

DIE THICKNESS: 0.0198 inches - 0.0218 inches

Ceramic Dual-In-Line Metal Seal Packages (SBDIP)

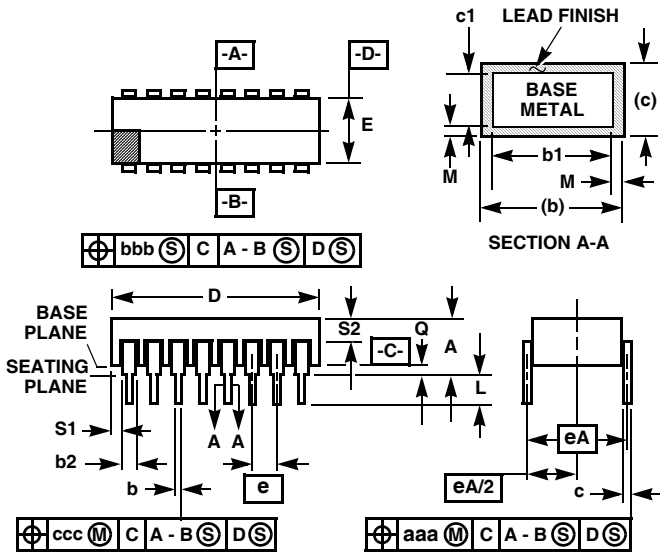

**D16.3 MIL-STD-1835 CDIP2-T16 (D-2, CONFIGURATION C)
16 LEAD CERAMIC DUAL-IN-LINE METAL SEAL PACKAGE**

SYMBOL	INCHES		MILLIMETERS		NOTES
	MIN	MAX	MIN	MAX	
A	-	0.200	-	5.08	-
b	0.014	0.026	0.36	0.66	2
b1	0.014	0.023	0.36	0.58	3
b2	0.045	0.065	1.14	1.65	-
b3	0.023	0.045	0.58	1.14	4
c	0.008	0.018	0.20	0.46	2
c1	0.008	0.015	0.20	0.38	3
D	-	0.840	-	21.34	-
E	0.220	0.310	5.59	7.87	-
e	0.100 BSC		2.54 BSC		-
eA	0.300 BSC		7.62 BSC		-
eA/2	0.150 BSC		3.81 BSC		-
L	0.125	0.200	3.18	5.08	-
Q	0.015	0.060	0.38	1.52	5
S1	0.005	-	0.13	-	6
S2	0.005	-	0.13	-	7
α	90°	105°	90°	105°	-
aaa	-	0.015	-	0.38	-
bbb	-	0.030	-	0.76	-
ccc	-	0.010	-	0.25	-
M	-	0.0015	-	0.038	2
N	16		16		8

NOTES:

1. Index area: A notch or a pin one identification mark shall be located adjacent to pin one and shall be located within the shaded area shown. The manufacturer's identification shall not be used as a pin one identification mark.
2. The maximum limits of lead dimensions b and c or M shall be measured at the centroid of the finished lead surfaces, when solder dip or tin plate lead finish is applied.
3. Dimensions b1 and c1 apply to lead base metal only. Dimension M applies to lead plating and finish thickness.
4. Corner leads (1, N, N/2, and N/2+1) may be configured with a partial lead paddle. For this configuration dimension b3 replaces dimension b2.
5. Dimension Q shall be measured from the seating plane to the base plane.
6. Measure dimension S1 at all four corners.
7. Measure dimension S2 from the top of the ceramic body to the nearest metallization or lead.
8. N is the maximum number of terminal positions.
9. Braze fillets shall be concave.
10. Dimensioning and tolerancing per ANSI Y14.5M - 1982.
11. Controlling dimension: INCH.

Rev. 0 4/94

All Intersil U.S. products are manufactured, assembled and tested utilizing ISO9000 quality systems. Intersil Corporation's quality certifications can be viewed at www.intersil.com/design/quality

Intersil products are sold by description only. Intersil Corporation reserves the right to make changes in circuit design, software and/or specifications at any time without notice. Accordingly, the reader is cautioned to verify that data sheets are current before placing orders. Information furnished by Intersil is believed to be accurate and reliable. However, no responsibility is assumed by Intersil or its subsidiaries for its use; nor for any infringements of patents or other rights of third parties which may result from its use. No license is granted by implication or otherwise under any patent or patent rights of Intersil or its subsidiaries.

For information regarding Intersil Corporation and its products, see www.intersil.com

Ceramic Metal Seal Flatpack Packages (Flatpack)

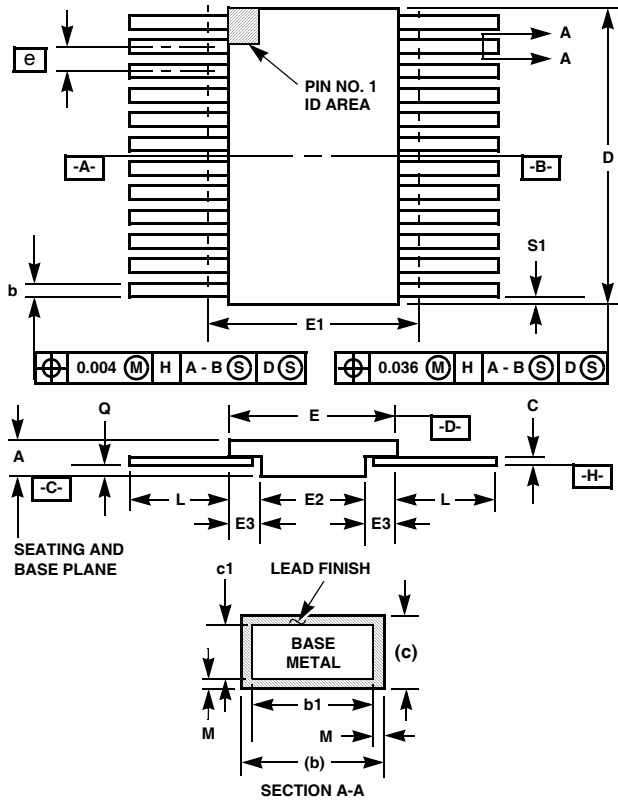

**K16.A MIL-STD-1835 CDFP4-F16 (F-5A, CONFIGURATION B)
16 LEAD CERAMIC METAL SEAL FLATPACK PACKAGE**

SYMBOL	INCHES		MILLIMETERS		NOTES
	MIN	MAX	MIN	MAX	
A	0.045	0.115	1.14	2.92	-
b	0.015	0.022	0.38	0.56	-
b1	0.015	0.019	0.38	0.48	-
c	0.004	0.009	0.10	0.23	-
c1	0.004	0.006	0.10	0.15	-
D	-	0.440	-	11.18	3
E	0.245	0.285	6.22	7.24	-
E1	-	0.315	-	8.00	3
E2	0.130	-	3.30	-	-
E3	0.030	-	0.76	-	7
e	0.050 BSC		1.27 BSC		-
k	0.008	0.015	0.20	0.38	2
L	0.250	0.370	6.35	9.40	-
Q	0.026	0.045	0.66	1.14	8
S1	0.005	-	0.13	-	6
M	-	0.0015	-	0.04	-
N	16		16		-

Rev. 1 2-20-95

NOTES:

1. Index area: A notch or a pin one identification mark shall be located adjacent to pin one and shall be located within the shaded area shown. The manufacturer's identification shall not be used as a pin one identification mark. Alternately, a tab (dimension k) may be used to identify pin one.
2. If a pin one identification mark is used in addition to a tab, the limits of dimension k do not apply.
3. This dimension allows for off-center lid, meniscus, and glass overrun.
4. Dimensions b1 and c1 apply to lead base metal only. Dimension M applies to lead plating and finish thickness. The maximum limits of lead dimensions b and c or M shall be measured at the centroid of the finished lead surfaces, when solder dip or tin plate lead finish is applied.
5. N is the maximum number of terminal positions.
6. Measure dimension S1 at all four corners.
7. For bottom-brazed lead packages, no organic or polymeric materials shall be molded to the bottom of the package to cover the leads.
8. Dimension Q shall be measured at the point of exit (beyond the meniscus) of the lead from the body. Dimension Q minimum shall be reduced by 0.0015 inch (0.038mm) maximum when solder dip lead finish is applied.
9. Dimensioning and tolerancing per ANSI Y14.5M - 1982.
10. Controlling dimension: INCH